

Andalay™

A Whole New Look to Solar Power



Designed for Maximum Reliability

Solar systems must last decades in the harsh environment of your roof. But years of sun, wind and rain can corrode the different metals and eat through unprotected wiring found on ordinary solar systems. Both lead to a failed investment. Andalay, the next generation in solar power systems, engineered away these flaws with its award-winning revolutionary design. Protected wiring, assembly in a quality-controlled factory environment, and superior framing, grounding and wiring deliver a system that is built to provide decades of reliable solar power performance.

Delivers Maximum Performance

With Enphase micro-inverters built right into each panel, Andalay delivers powerful performance over its 25 year lifetime. Unlike ordinary panels where their power production varies from hour to hour, each Andalay panel consistently operates at its maximum power potential. Additionally, these revolutionary panels continue to operate at maximum power even if one panel goes down compared to ordinary panels where the malfunction of one panel from shading or other failures takes down all of the panels. As a result, these revolutionary panels can perform 5% to 25% higher than ordinary panels.

Presents a Beautiful Design

In addition to its unparalleled reliability, Andalay's award winning design showcases a sleek, beautiful, design that compliments your home. With 80% less parts and fewer penetrations to your roof, Andalay's slimmer panels, invisible electrical cabling and hidden mounting system take up less room on your roof while showing off a revolutionary design. The end result is an attractive system that ends electricity bills and fights green house gas.

Andalay is an integrated solar power system

● Built-in Reliability & Safety

- No single point of system failure
- Built-in electrical and ground connectors cannot loosen or be installed incorrectly
- No dangerous 600 volt DC wiring
- Shorter wire lengths are less likely to fail by pinching or abrading
- 70% fewer roof-assembled parts means a longer lasting system
- 25% fewer roof attachment points means greater roof integrity
- Grounding process cannot skip panels, connectors will not wear or corrode

● High Performance

- 5 - 25% better performance than ordinary panels
- Built in microinverter delivers greater production in low light conditions on a per module basis
- Latest generation monocrystalline cell technology
- Output tolerance of just 3% means the promised power is delivered
- Lighter weight and less space between panels so more can fit on a roof
- Lower electrical resistance losses due to shorter wire lengths

● Convenience and Safety for Customer and Installer

- Andalay modules are UL listed and CSA certified and meet National Electrical Code requirements
- A lighter system that requires a single hand tool to install makes it safer for the installer
- Microinverters are fully compliant with UL 1703 solar test and National Electric Code requirements

● Beautiful Design

- No external racks or dangling wires for a clean, uncluttered look
- No bulky inverters or unsightly wiring
- No gaps between panels for a contiguous, smooth appearance
- Panels and all hardware are flat black – they look like skylights!

● Long Warranty

- 12/25 year power output Andalay module warranty provides confidence in purchasing today and protection in the future
- 15 Year Standard Microinverter Warranty

● Environmentally Sensitive

- No external cardboard packaging means less waste to dispose
- Lighter weight and fewer parts means fewer resources required to produce and less fuel needed to transport

Mechanical Specifications - Module

Length x Width	Thickness	Weight
62.6 x 32.2 inches	2.81 inches	45.7 lbs
159 x 82 cm	7.13 cm	20.7 kg

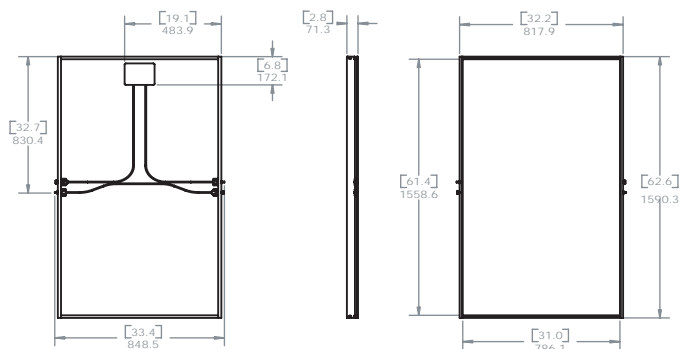

Electrical Characteristics at Standard Test Conditions

STC: irradiance of 1000W/m², spectrum AM 1.5g, and cell temperature of 25°C

ST175-1		
Peak Power ¹	P _{max}	175W
Output Tolerance		± 3%
Rated Current	I _{mp}	4.95A
Rated Voltage	V _{mp}	35.2V
Short-Circuit Current	I _{sc}	5.20A
Open-Circuit Voltage	V _{oc}	44.2V
Series Fuse Rating		15A
Maximum System Voltage		600V
Temperature Coefficients	Power	-0.5 %/°C (± 0.05)
	Voltage	-0.155 V/°C (± 0.01)
	Current	-0.06 %/°C (± 0.01)
Cell Technology		72 Cell Mono-Si, 125 x 125mm

¹Peak Power at Output Tolerance

Performance Characteristics

Current vs. Voltage at 22°C
ST170 -1

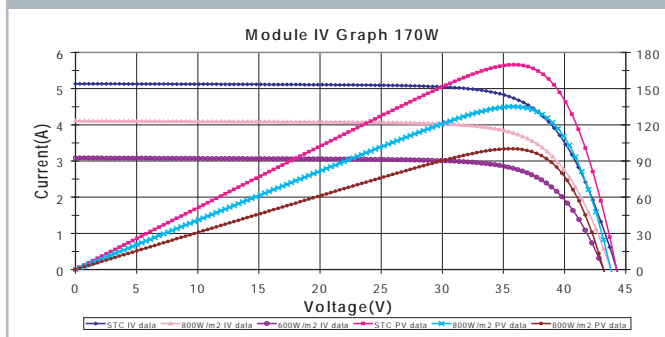

Mechanical Specifications - System

	ST175-1	Non-Andalay
Racking hardware	Integrated	External
Grounding wires	Integrated	External
Wiring connections	Factory-assembled	Installer-assembled
Module-module connections	Integrated (Threaded)	External (Friction Clips)
Space between modules	1/8"	Up to 3"
Roofing penetrations	25% Fewer	Standard

Micro-Inverter Technical Specifications

	M190-24-208-S01/2	M190-24-240-S01/2
Nominal output current	913mA	790mA
Nominal voltage/range	208V/183V-229V	240/211V-264V
Extended voltage/range	208V/179V-232V	240V/211V-269V
Nominal frequency/range	60.0/59.3-60.5	60.0/59.3-60.5
Extended frequency/range	60.0/59.3-60.5	60.0/59.3-60.5
Power factor	>0.95	>0.95
Maximum units per branch	21	15
Peak inverter efficiency	0.955	0.955
CEC weighted efficiency	0.95	0.95
Nominal MPP tracking	0.996	0.996
Operating temperature range	-40°C to +65°C	-40°C to +65°C
Night time power consumption	30mW	30mW
Cooling	Natural Convection - No Fans	
Enclosure environmental rating	Outdoor - NEMA 6	
Communication	Powerline	
Warranty	15 Years	
Compliance	UL1741/ieee1547	
	FCC Part 15 Class B	

Certified by

